



2265 Crosswind Drive • Prescott, AZ 86301
(928) 636-3175

4WAY STABILIZER SHOCKS

⚠ WARNING

Read and understand all instructions, warnings and safety precautions in these instructions and your owners manual before attempting to install these components.

PRODUCT SAFETY WARNING

Certain Performance Automotive Group products are intended to improve off-road performance. Modifying your vehicle for off-road use may result in the vehicle handling differently than a factory equipped vehicle. Use of oversized tires, suspension lifts, body lifts and other suspension modifications may raise your vehicle's center of gravity resulting in an increased tendency for the vehicle to pitch and roll during sudden turns or abrupt maneuvers. Extreme care must be used to prevent loss of control or vehicle roll over. Failure to drive your modified vehicle safely may result in serious injury or death. Drive at reduced speeds to ensure your ability to maintain control of the vehicle under all driving conditions. Always wear seat belts.

⚠ CAUTION

Proper installation of Performance Automotive Group products requires knowledge of recommended procedures for disassembly/assembly of OE vehicles and components. Access to OE shop manuals and special tools are required. Attempting to install this kit without knowledge of these procedures may affect the safety of your vehicle and/or the performance of these components. Performance Automotive Group strongly recommends that this kit be installed by a certified mechanic with off-road experience.

⚠ WARNING

This kit should only be installed on a vehicle that is in good working condition. Before you install the kit, thoroughly inspect the vehicle for corrosion or deformation of the sheet metal around the factory body mounts. If the vehicle is suspected to have been in a collision or misused, do not install this kit. Off-road use of your vehicle with this kit installed may increase the stress applied to the factory body mounts. We do not recommend that any vehicle with a body lift kit installed be involved in any extreme off-road maneuvers such as jumping. Failure to observe this warning may result in serious personal injury and/or severe damage to your vehicle.

Before Starting Installation

1. Carefully read all warnings and instructions completely before beginning.
2. Verify all parts have been received in this kit by checking the parts list at the end of this document
3. **Only install this kit on the vehicle for which it is specified.** If anytime during the installation you encounter something different from what is outlined in the instructions, call technical support at (928) 636-7080.

⚠ CAUTION

Performance Automotive Group recommends the use of Loctite® on all hardware, unless noted otherwise.

⚠ WARNING

Properly block and secure vehicle prior to installation.

Installation Instructions

△NOTE

Measurements for proper adjustment of 4Way Stabilizer Shocks **MUST** be made with vehicle on flat ground supporting it's own weight on the suspension.

1. Measure shock length from upper and lower mount at ride height.

△CAUTION

Preloading the stabilizer spring more than 1/2" from the correct neutral position in either compression or extension in order to use it as a lifting or lowering device will detract from the function of the stabilizer or damage the cylinder.

2. Sock absorbers with dust shield

- a. Before removing OE shock absorber make a mark around shock barrel at bottom of the dust shield.
- b. Mark vertical line from dust shield to shock body to note index of both shock ends.

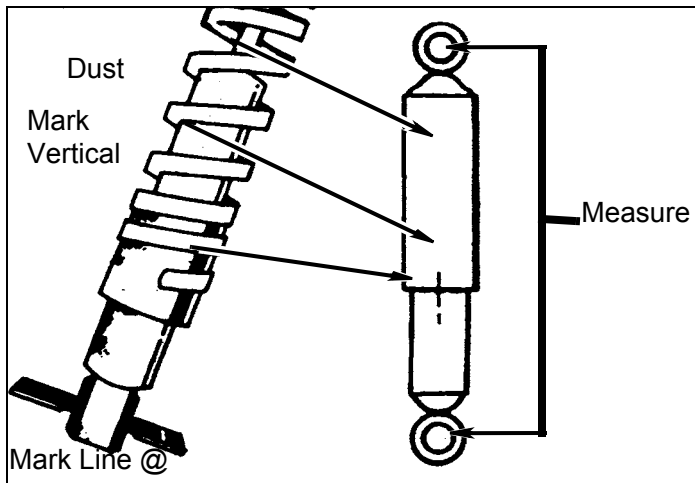

- c. Remove shock from vehicle.
- d. Use marks as guide and position shock to same length and index as installed on vehicle.
- e. Adjust *kit 4Way stabilizer* to same length and position as OE shock.
- f. Secure cap screws in lower collar.

- g. Repeat procedure for all shocks.

3. Stem type shock absorber without dust shield

- a. Measure shock while on vehicle at ride height from shock eyelet to end of shock shaft.
- b. Measure length of *kit 4Way stabilizer* and set to same length as OE measurement.
- c. Tighten cap screws.
- d. Mount on vehicle.

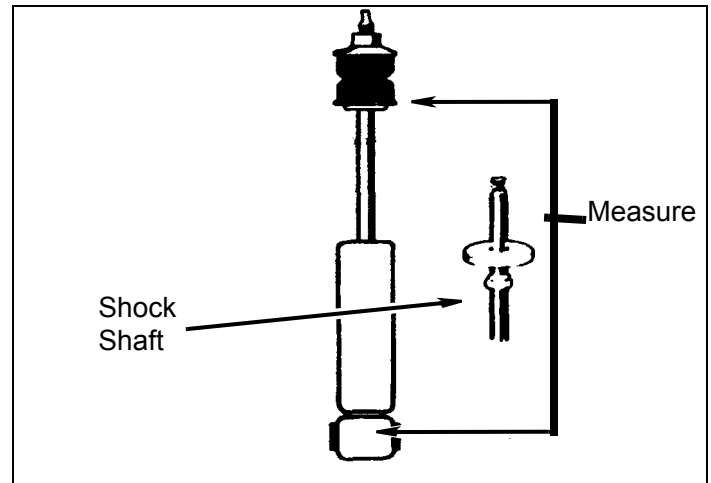

4. Non adjustable 4Way Stabilizer

Non-adjustable units are 2" OD and usually require no opening of lower control arm hole for installation.

When installing *kit 4Way stabilizer* through a coil spring on a front control arm it may help to compress the suspension spring by jacking up the opposite corner of the vehicle.

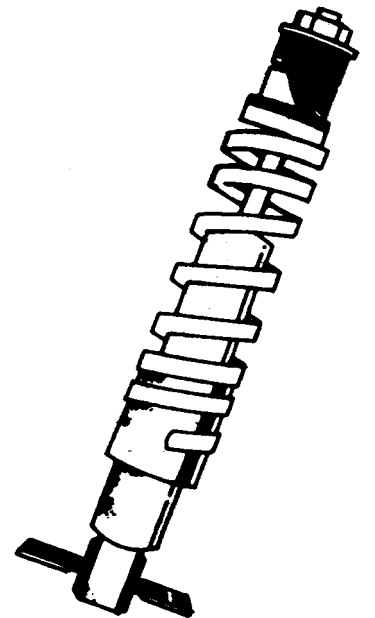

5. Adjustable 4Way stabilizer.

- a. **To lengthen unit:** Invert shock and grasp by lower end. Tap casting with hammer, driving casting down on shock barrel until desired length is reached.

△NOTE

Allen screws must be removed before adjustments are made. Ensure spring is turned all the way into casting grooves and align top and bottom mounts to fit vehicle before tightening cap screws.

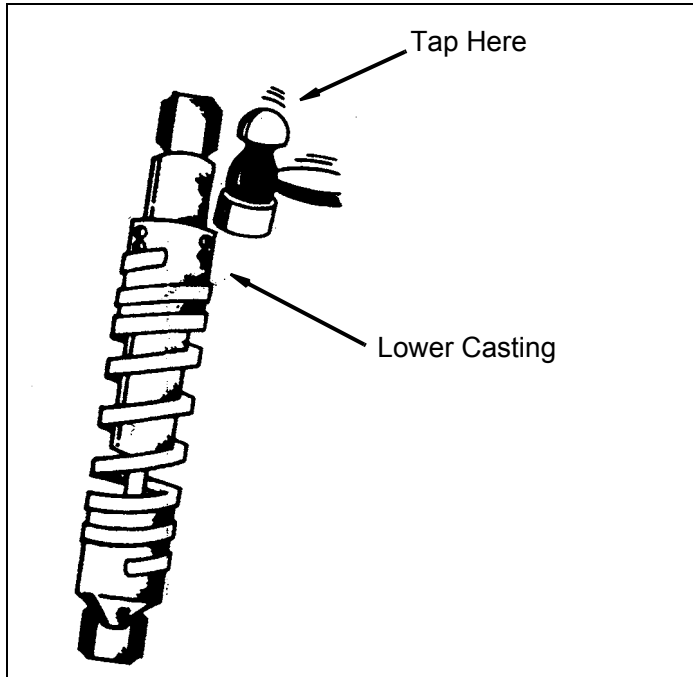

- b. **To shorten unit:** Grasp lower casting firmly and tap bottom mount with hammer. This will cause shock barrel to slide into casting to desired length.

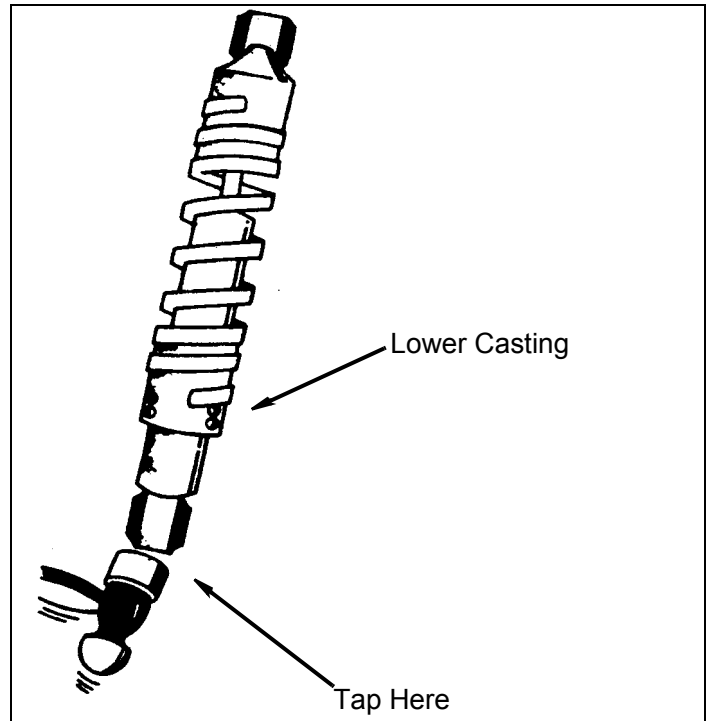

Rev. 01, Copyright 4/05
Performance Automotive Group

4WAY SUSPENSION PRODUCTS LIMITED LIFETIME WARRANTY

Trail Master warrants to the original retail purchaser that its suspension products are free from defect in material and workmanship for so long as such purchaser owns the vehicle on which such products were originally installed. For products installed on commercial vehicles this warranty shall extend for one year from the date of purchase only. Excluded from this warranty are the finish of the product and any product that has been altered, modified and/or installed contrary to the manufacturer's instructions. Suspensions not used in conjunction with **Trail Master** shock absorbers may void warranty. **Trail Master** suspension products are not designed nor intended to be installed on vehicles used in a race, or for racing purposes or similar activities. "Race" means any contest between two or more vehicles, or any contest of one or more vehicles against the clock, whether or not such contest is for a prize.

Trail Master's obligation under this warranty is limited to the repair or replacement, at **Trail Master's** option, of the defective product. Any cost of removal, installation or reinstallation, freight charges, incidental or consequential damages are expressly excluded from this warranty. **This warranty is expressly in lieu of all other warranties express or implied, including the implied warranties of merchantability and fit-**

ness for use, and all other obligations or liabilities on the part of Trail Master for products installed on commercial vehicles. Trail Master can neither assume or authorize any other person to assume for us any other liability in connection with the sale of this product. This warranty shall not apply to any product that has been subject to accident, negligence, alteration, abuse or misuse. We make no warranty whatsoever in respect to products not supplied by us.

To make a claim under this Warranty, Purchaser must (1) call **Trail Master** at (928) 636-3175 for a return authorization; (2) return the defective component, postage prepaid, together with the dated proof of purchase to Trail Master Products, 2265 Crosswind Drive, Prescott, Az. 86301.

There are no warranties, express or implied including any implied warranties of merchantability and fitness, that extend beyond the warranty period.

This warranty gives you specific legal rights including other rights which may vary from state to state. Some states do not allow limitations on how long an implied warranty lasts, or do not allow exclusion on limitation of incidental or consequential damages, so the above limitations and/or exclusions may not apply to you.