



2265 Crosswind Dr. • Prescott, AZ 86301  
(928) 636-3175 • www.p-a-g.net

**DODGE RAM 4WD  
2" LEVELING KIT  
(COIL SPRING SPACERS)  
INSTALLATION INSTRUCTIONS**  
**1994-2001 1500,                   KIT# DL220**  
**1994-2006 2500/3500   KIT# DL221**

**⚠ WARNING**  
Installation of a Performance Automotive Group body lift kit will change the vehicle's center of gravity and handling characteristics both on- and off-road. You must drive the vehicle safely! Extreme care must be taken to prevent vehicle rollover or loss of control, which could result in serious injury or death. Avoid sudden sharp turns or abrupt maneuvers and always make sure all vehicle occupants have their seat belts fastened.

**⚠ WARNING**  
Before you install this kit, read and understand all instructions, warnings, cautions, and notes in this instruction sheet and in the vehicle owner's manual.

**⚠ CAUTION**  
Proper installation of this kit requires knowledge of the factory recommended procedures for removal and installation of original equipment components. We recommend that the factory shop manual and any special tools needed to service your vehicle be on hand during the installation. Installation of this kit without proper knowledge of the factory recommended procedures may affect the performance of these components and the safety of the vehicle. We strongly recommend that a certified mechanic familiar with the installation of similar components install this kit.

**⚠ WARNING**  
DO NOT combine suspension, body, or other lift devices. Use of vehicle with combined lifts may result in unsafe and/or unexpected handling characteristics.

**⚠ WARNING**  
This kit should only be installed on a vehicle that is in good working condition. Before you install the kit, thoroughly inspect the vehicle for corrosion or deformation of the sheet metal around the factory body mounts. If the vehicle is suspected to have been in a collision or misused, do not install this kit. Off-road use of your vehicle with this kit installed may increase the stress applied to the factory body mounts. We do not recommend that any vehicle with a body lift kit installed be involved in any extreme off-road maneuvers such as jumping. Failure to observe this warning may result in serious personal injury and/or severe damage to your vehicle.

**⚠ WARNING**  
Many states and municipalities have laws restricting bumper heights and vehicle lifts. Consult state and local laws to determine if the changes you intend to make to the vehicle comply with the law.

**⚠ WARNING**  
The installation of larger tires may reduce the effectiveness of the braking system.

**⚠ WARNING**  
Always wear eye protection when operating power tools.

**⚠ WARNING**  
Before you install this kit, block the vehicle tires to prevent the vehicle from rolling.

**⚠ WARNING**  
Accidental deployment of the air bag can result in serious personal injury or death. To avoid accidental deployment during installation of the kit, the Supplemental Restraint System (SRS, or airbag) must remain deactivated. Do not allow anyone near the airbag during installation. Refer to the factory service manual or owner's manual for the recommended procedure to disable the SRS. After you install the kit, reactivate the SRS before driving the vehicle.

**NOTE**  
Performance Automotive Group recommends using the Loctite® supplied in the kit on the threads of all kit nuts and bolts unless specified otherwise in these instructions.

# Before Starting Installation

## NOTE

Kit parts are prefaced by the word *kit* and appear in **bold** print.

1. Carefully read all warnings and instructions completely before beginning.
2. Verify all parts have been received in this kit by checking the parts list at the end of this document.

## NOTE

If parts are missing from kit, please be prepared to provide the following information:

1. **Name** of purchase location
  2. **Bar Code** on side of box
  3. **Date** above bar code
  4. **Date** inside box cover
  5. **Inspector #** from inside box cover
3. **Only install this kit on the vehicle for which it is specified.** If anytime during the installation you encounter something different from what is outlined in the instructions, call technical support at (928) 636-3175.
  4. Special tools needed:
    - a. Spring compressors
  5. Park vehicle on a clean, dry, flat, level surface and block tires so vehicle cannot roll in either direction.

## Engine Compartment

1. Batteries
  - a. Disconnect both negative cables (1) first, then positives cable (2) from both batteries (3).

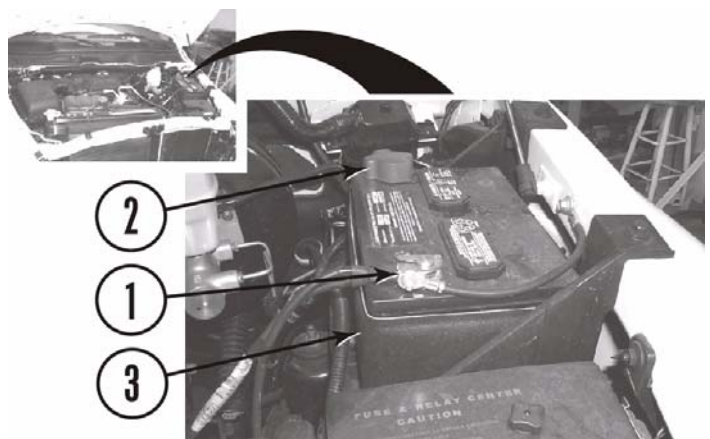

# Prepare to Install Kit

## 1. Front axle

- a. If equipped, remove two caps (4) from front wheels (5).
- b. Loosen eight lug nuts (6) each from two front wheels (5).
- c. Using a hydraulic jack, slowly lift front axle (7) so that two front tires (8) are three to five inches off of ground. Position jack stands under frame (9). Lower frame onto jack stands. DO NOT remove hydraulic jack and maintain some hydraulic jack pressure on axle.
- d. Remove eight lug nuts (6) each and two front wheels (5) from axle (7).

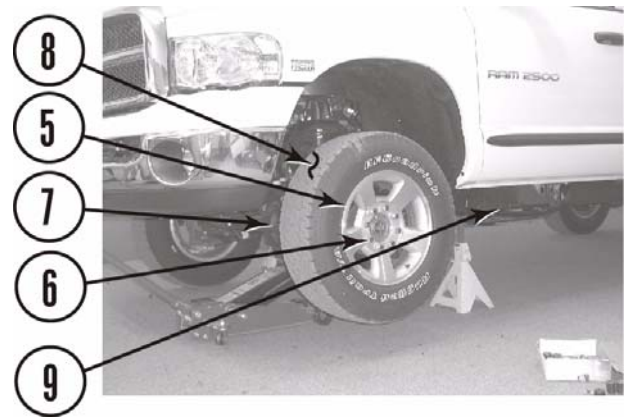
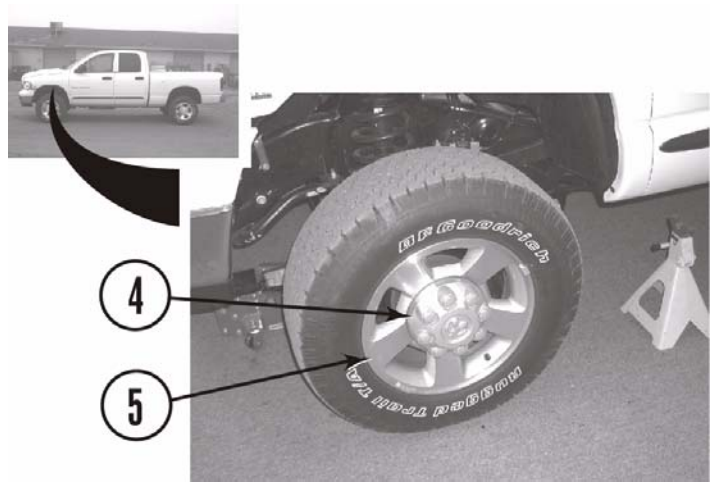

## 2. Shocks, sway bar, and coil springs

- a. Remove bolt (10), nut (11), and shock (12) from front axle (7).
- b. Remove nut (13), washer (14), bushing (15) and sway bar link (16) from sway bar (17).
- c. Lower front axle (7). DO NOT remove hydraulic jack from axle.

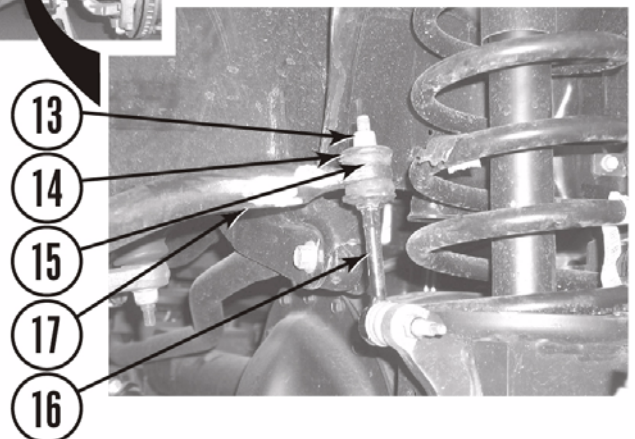
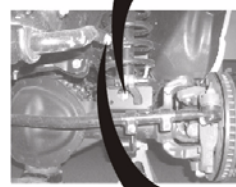
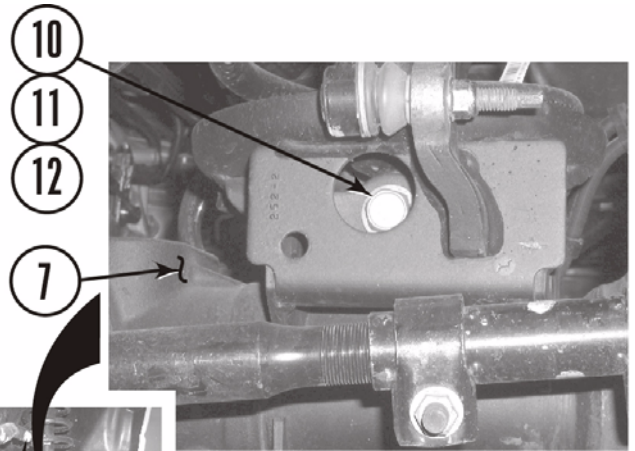

- d. Remove vent line (18) and vent line clip (19) from shock tower (20).
- e. Remove three nuts (21), shock tower (20), and shock (12) from coil spring stud ring (22) and coil spring perch (23).

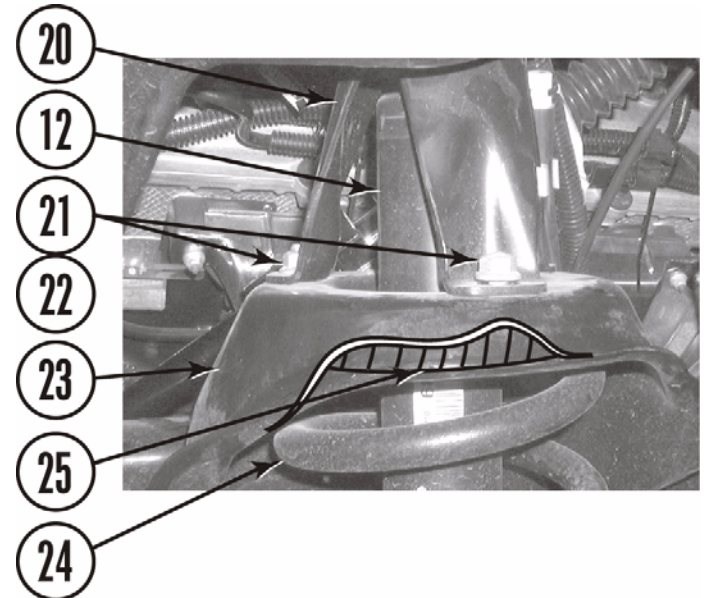
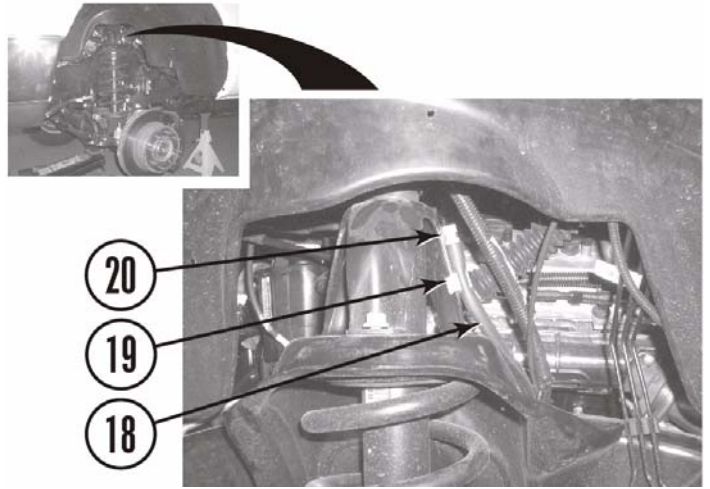

**⚠ WARNING**  
 Compressed coil springs can expand violently causing serious personal injury. Before removing the coil springs, lower the axle housing as far as possible to allow the coil springs to expand. Use caution when using coil spring compressors.

- f. Lower front axle (7), remove coil spring (24), coil spring bushing (25) and coil spring stud ring (22) from coil spring perch (23). DO NOT remove hydraulic jack from axle.

## Install Kit

### 1. Coil springs

- a. Position *kit spacer* (coil spring) (26) onto coil spring perch (23).

**⚠ WARNING**  
 Compressed coil springs can expand violently causing serious personal injury. Before removing the coil springs, lower the axle housing as far as possible to allow the coil springs to expand. Use caution when using coil spring compressors.

- b. Compress coil spring (24) with coil spring compressors. Install compressed coil spring onto *kit spacer* (coil spring) (26) and axle (7).
- c. Slowly remove coil spring compressors from coil spring (24). Ensure *kit spacer* (coil spring) studs (27) are positioned into factory coil spring perch holes (28).

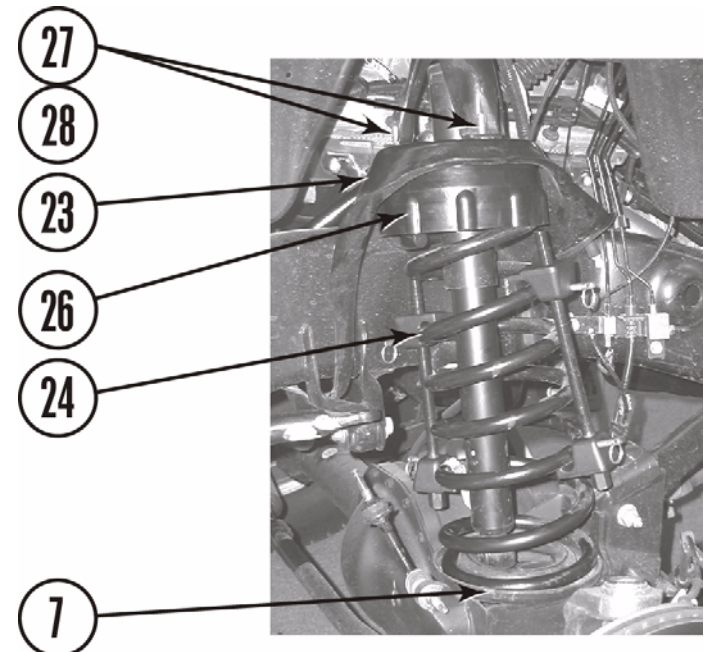

**NOTE**

Performance Automotive Group recommends using *kit Loctite®* supplied in the kit for all mounting hardware.

- d. Apply small amount of *kit Loctite®* onto threads of *kit spacer* (coil spring) studs (27).
  - e. Install *kit spacer* (coil spring) (26), shock tower (20), and shock (12) onto coil spring perch (23) with three *kit washers* (7/16" USS) (29) and *kit nuts* (7/16" Nylock) (30). TIGHTEN nuts to 10 lb-ft.
  - f. Lift axle (7) with hydraulic jack and install shock (12) onto axle with bolt (10) and nut (11).
  - g. Install sway bar link (16) onto sway bar (17) with bushing (15), washer (14), and nut (13).
  - h. Install vent line (18) and vent line clip (19) onto shock tower (20).
2. Repeat above steps for passenger side front axle (7).

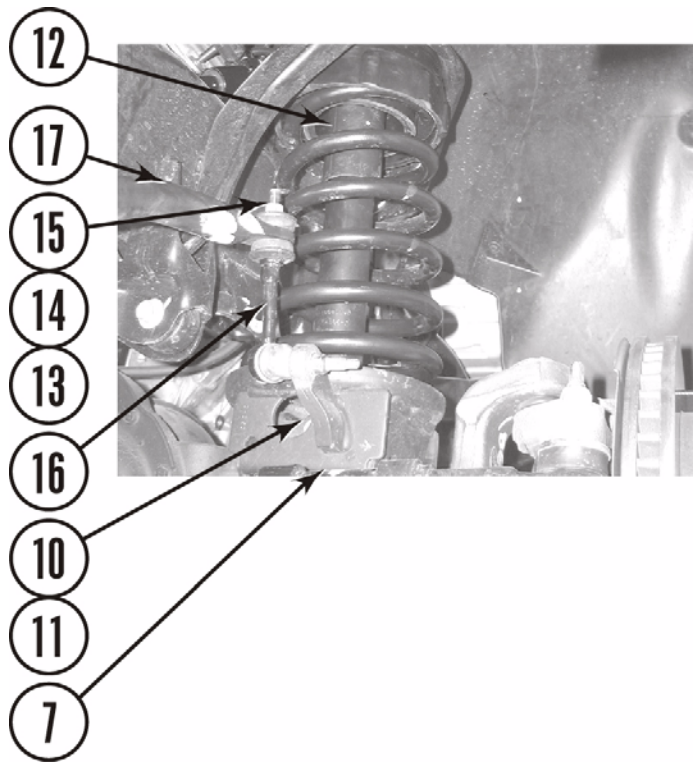
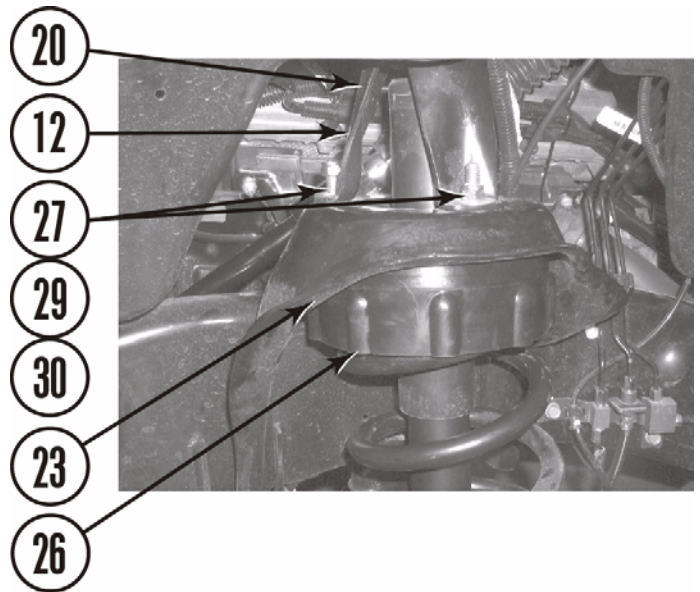

3. Front axle

- a. Install two front wheels (5) onto front axle (7) with eight lug nuts (6) each.
- b. Using a hydraulic jack, slowly lift front axle (7) so front tires (8) are three to five inches off of ground. Remove jack stands from frame (9). Lower vehicle onto ground and TIGHTEN sixteen lug nuts (6) to OE specification.
- c. If removed, install two caps (4) onto front wheels (5).



# After Completing Installation

## Engine Compartment

1. Batteries
  - a. Connect both positive cables (2) first, then both negative cables (1) on both batteries (3).

## Miscellaneous

1. Apply **kit label** (warning) onto dashboard in plain sight of all vehicle occupants.
2. Check all fasteners to ensure they are tight.
3. Ensure all wires, hoses, cables, etc. are properly connected and there is ample slack.
4. Adjust headlights.
5. Align vehicle to OE specifications. Retain alignment results.

## Dynamic Vehicle Check

1. Check steering and suspension in all positions to ensure that there is no bind and adequate clearance between all moving, fixed, and heated members. Check operation of clutch, brake system, and parking brake. Check operation of transmission and transfer case. Ensure there is full engagement in all gears and 4WD ranges. Check battery connections and electrical component operations. Test-drive vehicle.

## Kit Parts List

Qty.	Description	Callout
2	<b>Spacer</b> (coil spring)	(26)
1	<b>Loctite®</b> , 6mL bottle	
1	<b>Label</b> (warning)	
1	<b>Label</b> (logo)	
6	<b>Nut</b> (7/16" Nylock)	(30)
6	<b>Washer</b> (7/16" USS)	(29)

### NOTE

Depending on the vehicle configuration (automatic or manual transmission, 2WD or 4WD, cab length, bed length, etc.), some parts may not be used.



### ⚠WARNING

Retorque all fasteners after 500 miles and after off road use. All body lift components should be visually inspected and fasteners retorqued during routine vehicle servicing.

### ⚠CAUTION

Performance Automotive Group does not recommend any particular wheel and tire combinations for use with its body lifts and cannot assume responsibility for the customer's choice of wheels and tires. Refer to your owner's manual for recommended tire sizes and warnings related to the use of oversized tires. Larger wheel and tire combinations increase stress and wear on steering and suspension components, which leads to increased maintenance and higher risk for component failure. Larger wheel and tire combinations also alter speedometer calibration, braking effectiveness, center of gravity, and handling characteristics. Consult an experienced local off road shop to find what wheel and tire combinations work best with your vehicle.

### NOTE

All warranty information, instruction sheets, and other documents regarding the installation of this product must be retained by the vehicle owner. Information contained in the instructions and on the warranty card will be required for any warranty claims. The vehicle owner needs to understand the modifications made to the vehicle and how they affect vehicle handling and performance. Failure to provide the customer with this information can result in damage to the vehicle and severe personal injury.

Rev. 02 Copyright 02/06  
Performance Automotive Group  
www.p-a-g.net