



2265 Crosswind Drive • Prescott, AZ 86301
(928) 636-3175 • www.p-a-g.net

JEEP WRANGLER/RUBICON (TJ) JEEP UNLIMITED (TJL) 2" SUSPENSION LIFT (COIL SPRING SPACERS) INSTALLATION INSTRUCTIONS

1997-2006 KIT # JTJ22 N
1997-2006 KIT # JTJ22 S
1997-2006 KIT # JTJ22 SSV

⚠ WARNING

Read and understand all instructions, warnings and safety precautions in these instructions and your owner's manual before attempting to install these components.

⚠ CAUTION

Proper installation of Performance Automotive Group products requires knowledge of recommended procedures for servicing vehicles in original equipment condition. Access to factory shop manuals and special tools are required. Attempting to install this kit without knowledge of these procedures may affect the safety of your vehicle and/or the performance of these components. Performance Automotive Group strongly recommends that a certified mechanic with off road experience install this kit.

⚠ PRODUCT SAFETY WARNING

Certain Performance Automotive Group products are intended to improve off-road performance. Modifying your vehicle for off-road use may result in the vehicle handling differently than a factory equipped vehicle. Use of oversize tires, suspension lifts, body lifts and other suspension modifications may raise your vehicle's center of gravity resulting in an increased tendency for the vehicle to pitch and roll during sudden turns or abrupt maneuvers. Extreme care must be used to prevent loss of control or vehicle roll over. Failure to drive your modified vehicle safely may result in serious injury or death. Drive at reduced speeds to ensure your ability to maintain control of the vehicle under all driving conditions. Always wear seat belts.

⚠ WARNING

Performance Automotive Group does not recommend combined use of suspension lifts, body lifts or other lift devices. Combined use of lifts may result in unsafe and unexpected handling characteristics. (See warning above). Also, many states now have laws restricting vehicle lift, bumper heights and other alterations. Consult local laws to determine if your proposed alterations (including installation of this kit) comply with your state laws.

⚠ PRODUCT SAFETY WARNING

Supplied in kit is a Safety Warning label. Install label inside cab. Locate label in a highly visible location to all operators of this vehicle.

⚠ WARNING

The installation of larger tires may reduce the effectiveness of the Braking System.

⚠ WARNING

This kit is only intended for use on trucks that are in good condition. Before installing these components, thoroughly inspect truck, paying particular attention to the condition of the original equipment mounts and surrounding sheet metal. Do not install on trucks that show any evidence of corrosion, deformation of mounts or surrounding sheet metal. Do not install on trucks you suspect may have been involved in accidents or mis-used. Off road use of this product may increase the stresses applied to the original equipment mounts. Do not "jump" trucks equipped with body blocks. Check torque of fasteners frequently and include the mount areas in your routine safety inspections. Failure to follow this warning may result in damage to your vehicle and/or serious personal injury.

⚠ WARNING

Performance Automotive Group does not recommend that this kit be installed on vehicles with oversize tires and an Anti-Lock Brake System (ABS) because the effectiveness of the ABS will be reduced.

⚠ NOTE

After installation, the driveshaft(s) may vibrate and it may be necessary to replace the driveshaft "U"-joints more frequently. The angle of the rear driveshaft can be changed by changing the angle of the rear pinion using TrailMaster Kit 40170.

⚠ WARNING

Performance Automotive Group recommends using the Loctite® supplied in the kit on the threads of all kit nuts and bolts unless specified otherwise in these instructions.

Before Starting Installation

1. Carefully read all warnings and instructions completely before beginning.
2. Verify all parts have been received in this kit by checking the parts list at the end of this document.
3. **Only install this kit on the vehicle for which it is specified.** If anytime during the installation you encounter something different from what is outlined in the instructions, call technical support at (928) 636-3175.
4. Park the vehicle on a clean, dry, flat, level surface and block the tires so the vehicle cannot roll in either direction.

Torque Specifications

10mm 30 ft. lbs.

Parts List

<u>Qty.</u>	<u>Description</u>
4	Block , bump stop extension
4	Bolt , 10mm x 80mm
1	Label , warning
2	Shock absorber , front (N, SS, or SSV)
2	Shock absorber , rear (N, SS, or SSV)
4	Spacer , coil spring
4	Washer , 3/8" flat

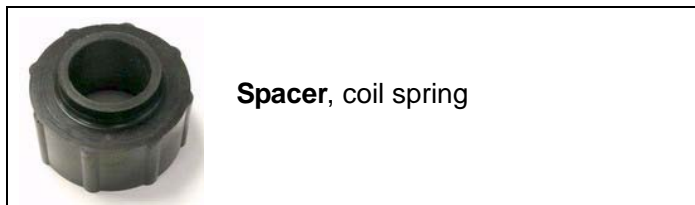
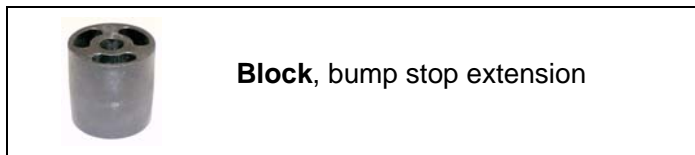

Install Kit

Front Axle

1. Preparation
 - a. Raise the front of the vehicle and support it under the frame (NOT under the front axle).
 - b. Place a hydraulic jack under the front axle with just enough pressure applied to support it.
2. Driveshaft
 - a. Paint or scribe alignment marks on the front driveshaft yoke and the pinion shaft.

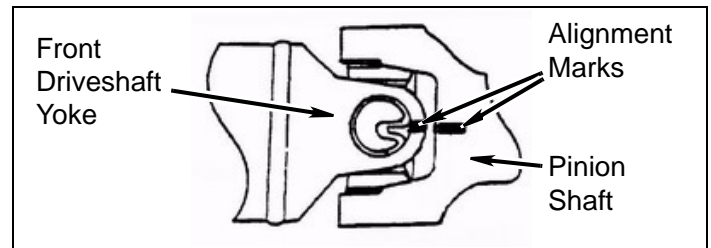

- b. Remove the bolts and "U"-joint straps from the pinion shaft.
 - c. Disconnect the front driveshaft from the pinion shaft.

3. Lower Control Arms

- a. Paint or scribe alignment marks on the adjuster cams and the brackets where the lower control arms are connected to the front axle.

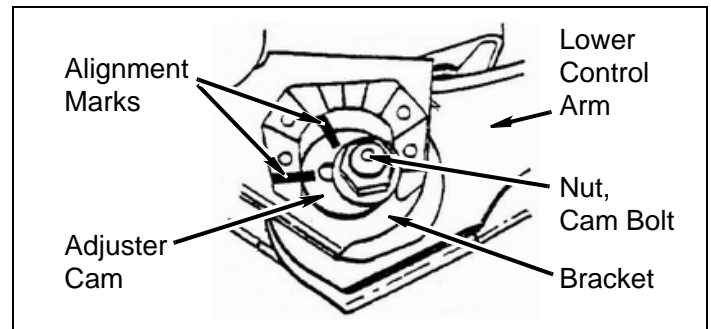

- b. Remove the nuts, adjuster cams, and cam bolts from the lower control arms and front axle.
 - c. Disconnect the lower control arms from the front axle.

4. Stabilizer Bar (Sway Bar)

- a. Disconnect the stabilizer bar links from the front axle.

5. Shock Absorbers

- a. Remove the front shock absorbers.

6. Track Bar

- a. Remove the cotter pin and nut securing the front track bar to the frame bracket.
- b. Use a puller to separate the track bar ball stud from the frame bracket.

7. Drag Link

- a. Remove the cotter pin and nut securing the drag link to the pitman arm.
- b. Use a puller to separate the drag link ball stud from the pitman arm.

8. Coil Springs

- a. Lower the front axle and remove the front coil springs.

9. Driver Side: Kit Spacer

- a. Remove the bump stop from the bump stop pocket.
- b. Remove the bolt and bump stop pocket from the factory bump stop extension.

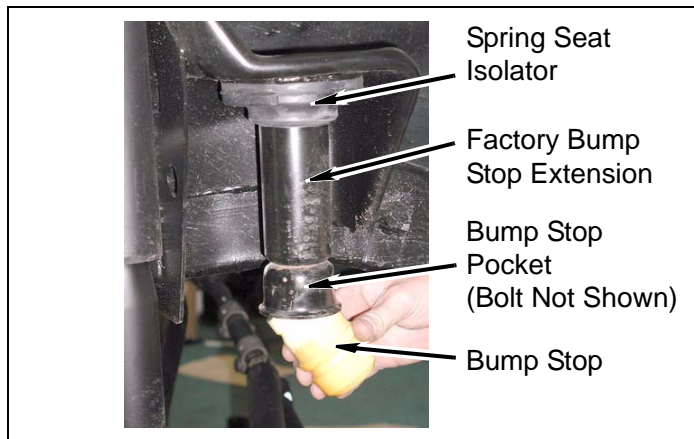

- c. Install the spring seat isolator (if removed) and the kit **spacer** on the factory bump stop extension.

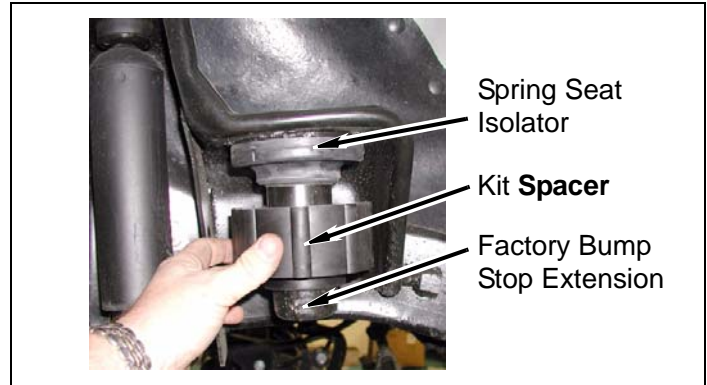

- d. Install a kit **block** (bump stop extension) and the bump stop pocket on the factory bump stop extension with a kit **bolt** (10mm x 80mm) and kit **washer** (3/8").

- e. Install the bump stop in the bump stop pocket.

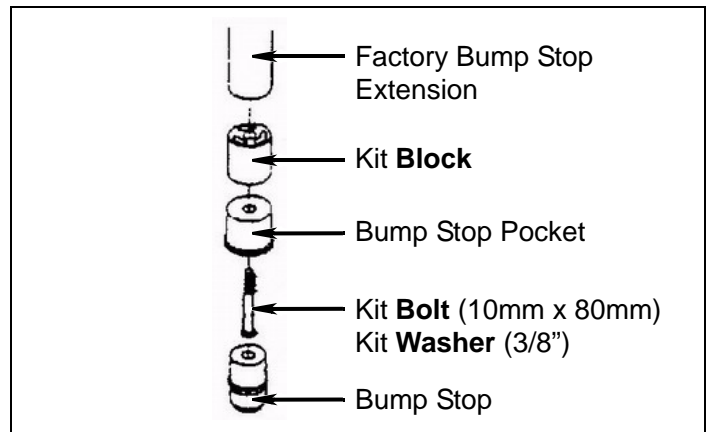

10. Passenger Side: Kit Spacer

- a. Repeat the above procedure to extend the bump stop and install the kit **spacer**.

11. Coil Springs

- a. Install the coil springs. Using the hydraulic jack, raise the front axle until the coil springs are seated against the kit **spacers**, then raise the front axle an additional 2".

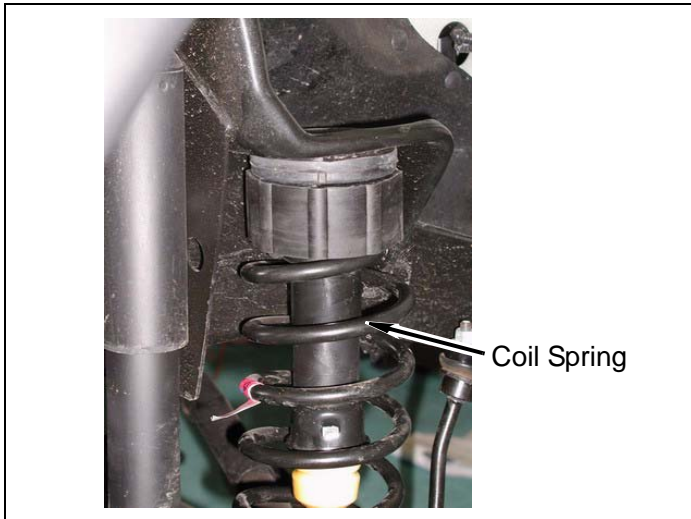

12. Stabilizer Bar (Sway Bar) Links

- a. Connect the stabilizer bar links to the front axle.

13. Shock Absorbers

- a. Install the front shock absorbers. Tighten the upper mounting nuts to 17 ft. lbs. Tighten the lower mounting nuts to 21 ft. lbs.

14. Track Bar

- a. Install the track bar ball stud on the frame bracket. If necessary, pry the front axle assembly to the left or right until the ball stud aligns with the hole in the frame bracket.
- b. Install the nut on the ball stud. Tighten the nut to 65 ft. lbs.

⚠ WARNING

DO NOT loosen the nut to align the cotter pin with the slots in the nut. Instead, tighten the nut until the cotter pin aligns with the slots.

- c. Install a new cotter pin.

15. Lower Control Arms

- a. Install the lower control arms on the axle brackets with the cam bolts, cams, and nuts. Fingertighten the nuts; DO NOT fully tighten at this time.

16. Driveshaft

- a. Install the front driveshaft on the axle pinion. Ensure the reference marks are aligned.
- b. Install the "U"-joint straps and bolts. Tighten the bolts to 14 ft. lbs.

17. Drag Link

- a. Install the drag link ball stud on the pitman arm.
- b. Install the nut on the ball stud. Tighten the nut to 60 ft. lbs.

⚠ WARNING

DO NOT loosen the nut to align the cotter pin with the slots in the nut. Instead, tighten the nut until the cotter pin aligns with the slots.

- c. Install a new cotter pin.

18. Lower Control Arms

- a. Lower the vehicle to the ground.
- b. Align the painted or scribed marks where the lower control arms are attached to the front axle. Tighten the nuts to 85 ft. lbs.

Rear Axle

1. Preparation

- a. Raise the rear of the vehicle and support it under the frame (NOT under the rear axle).
- b. Place a hydraulic jack under the rear axle with just enough pressure applied to support it.

2. Stabilizer Bar (Sway Bar) Links

- a. Disconnect the stabilizer bar links from the rear axle.

3. Shock Absorbers

- a. Remove the rear shock absorbers.

4. Track Bar

- a. Disconnect the rear track bar from the frame bracket.

5. Coil Springs

- a. Lower the rear axle and remove the rear coil springs.

6. Driver Side: Kit Spacer

- a. Remove the bump stop from the bump stop pocket.
- b. Remove the bolt and bump stop pocket from the spring seat.

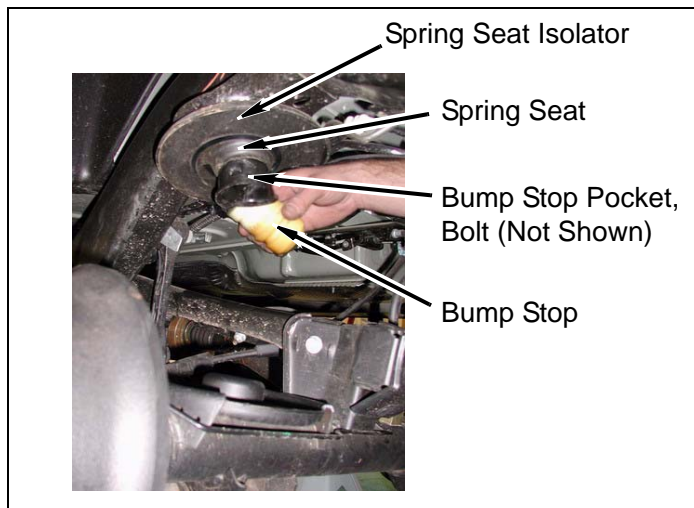

- c. Install the spring seat isolator (if removed) and a kit **spacer** on the spring seat.

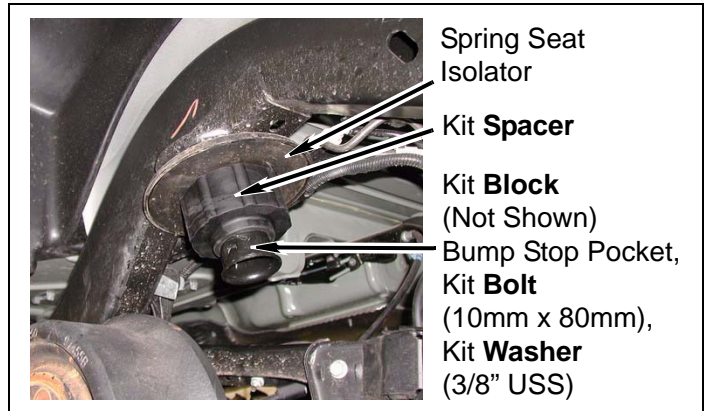

- d. Install a kit **block** (bump stop extension) and the bump stop pocket on the spring seat with a kit **bolt** (10mm x 80mm) and a kit **washer** (3/8").

- e. Install the bump stop in the bump stop pocket.

7. Passenger Side: Kit Spacer

- a. Repeat the above procedure to extend the bump stop and install the kit **spacer**.

8. Coil Springs

- a. Install the coil springs. Using the hydraulic jack, raise the rear axle until the coil springs are seated against the kit **spacers**, then raise the rear axle an additional 2".

9. Stabilizer Bar (Sway Bar) Links

- a. Connect the stabilizer bar links to the front axle. Tighten the bolts to 40 ft. lbs.

10. Shock Absorbers

- a. Install the rear shock absorbers. Tighten the upper mounting nuts to 23 ft. lbs. Hand-tighten the lower mounting nuts. **DO NOT** tighten at this time.

11. Track Bar

- a. Install the track bar on the frame bracket. If necessary, pry the rear axle assembly to the left or right until the holes are aligned.
- b. Hand-tighten the nut and bolt. DO NOT tighten at this time.

12. Remaining Nuts and Bolts

- a. Lower the vehicle to the ground.
- b. Tighten the lower shock mounting nuts to 74 ft. lbs.
- c. Tighten the track bar mounting bolt to 74 ft. lbs.

- b. Check all fasteners for proper torque. Check to ensure there is adequate clearance between all fixed and moving parts including exhaust components, brake lines, fuel lines, fuel tank, floor board, and wiring harnesses. Check the steering system for interference and proper working order. Check the brake lines for damage. Test the brake system.

- c. After installation it may be necessary to replace the brake hoses with longer ones to ensure there is adequate slack in the hoses when the suspension is fully unloaded. (Longer hoses may be available through your local parts supplier.) Perform a steering sweep test to ensure the brake hoses have sufficient slack and will not contact other parts. Failure to perform this check (and replace the brake hoses, if necessary) may result in component failure!

- d. Retain this instruction sheet and all information regarding your altered vehicle for future reference. Thank you for choosing TrailMaster. For questions or suggestions, contact TrailMaster at (928) 636-3175.

After Completing Installation

1. Warning Label

- a. Install the kit label (warning) in the cab so it can easily be seen by all occupants of the vehicle. If the kit label is lost or damaged, call TrailMaster at (928) 636-3175 to request a replacement.

2. Headlights

- a. Adjust the headlights.

3. Alignment

- a. Align the vehicle to manufacturer's specification. The size of rim and tire combination should be considered when making front end adjustments. Always use a spare tire of equal size to the other tires on the vehicle.

4. Miscellaneous

- a. TrailMaster's goal is to provide you with the best system possible for a reasonable cost. The components in your TrailMaster kit do not eliminate weaknesses that may exist in the original equipment components.

⚠ CAUTION

Retorque all fasteners after 500 miles and every off road use. Visually inspect components and retorque fasteners during routine vehicle service.

⚠ CAUTION

TrailMaster does not recommend a particular tire and wheel combination for use with its products and assumes no responsibility for customer choice of tires and wheels. Consult your vehicle owner's manual for recommended tire sizes and warnings related to use of oversize tires and wheels. In general, larger tire and wheel combinations may increase stress and wear on steering components leading to increased maintenance and greater risk of component failure, including loss of steering control. Property damage or personal injury may result. Large tire and wheel combinations may also alter speedometer calibration, reduce braking effectiveness, and alter the vehicle center of gravity. (See the product safety warnings above). Check with an experienced offroad shop for the tire and wheel combinations that work best on your truck. Remember, BIG isn't necessarily better.

Rev. 01, Copyright 07/06
Performance Automotive Group
www.p-a-g.net